

G4HUP

Distribution Amplifier

Technical Manual



Document Author	Dave Powis, G4HUP
Date	13 Aug 2015
Version	Issue 2.03
Document Ref	HUP-05-020

Contents

Unit Specifications.....	3
<i>Scope of Document</i>	5
<i>DA1-4 Distribution Amplifier Description</i>	6
GP DA V2.00 PCB Description.....	6
Unused Channels.....	8
Version - DA-HL	8
Typical Applications	9
Version – DA-RF	9
Typical Applications	10
<i>Sundry Information</i>	10
Filtering & Isolation.....	10
Connectors.....	10
Output Phase Equalisation.....	10
<i>Version Construction Notes</i>	11
DA1-4HL.....	11
DA1-4RF	12
Case Preparation.....	13
<i>Errata and Addenda</i>	14
<i>Component Locations</i>	14
<i>Performance - DA1-4HL</i>	14
<i>Maintenance</i>	15
Construction Practices.....	15
Change History.....	15
<i>Component List DA1-4HL</i>	16
<i>Component List DA1-4RF</i>	17
Appendix 1 – Pi Attenuator Resistor Values	26

Unit Specifications

Model Ref High Level Distribution Amplifier DA1-4HL

Serial No

Input Frequency ¹	10	MHz
Input Level	+0	dBm (Max i/p +5dBm)
Output Frequency	10	MHz
Output Level ²	+5	dBm per channel (0dB Atten)
Gain Variation between channels	<4%	At 10MHz
Phase variation between channels	<±3°	At 10MHz
Inter-channel Isolation	>25	dB typ. at 10MHz
Max output	+10	dBm (recommended)
Supply Voltage	10 – 15	V
Supply Current	300	mA @ 13.4vdc

Notes:

- 1 The High Level DA is broadband in nature, but measurements quoted here have been conducted at 10MHz.
- 2 Output level quoted is without any attenuators in the circuit.
- 3 Power level measurements quoted here have been taken with HP435 Power Meter.

Model Ref Low Level Distribution Amplifier DA1-4RF

Serial No

Input Frequency ¹	10	MHz
Input Level	-20	dBm (Max i/p +5dBm)
Output Frequency	10	MHz
Output Level ²	+8	dBm per channel (0dB Atten)
Gain Variation between channels	<4%	At 10MHz
Phase variation between channels	<±3°	At 10MHz
Inter-channel Isolation	>25	dB typ. at 10MHz
Max output	+10	dBm (recommended)
Supply Voltage	10 – 15	V
Supply Current	350	mA @ 13.4vdc

Typical performance measurements:

Frequency (MHz)	Gain (dB)	Noise Figure (dB)
16	27.5	2.85
50	27.5	2.8
144	26.5	2.9
220	25.5	3.0
435	19	4.0
1296	12	8

Notes:

- 1 The Low Level DA is broadband in nature, but measurements quoted here have been conducted at 10MHz.
- 2 Output level quoted is without any attenuators in the circuit.
- 3 Power level measurements quoted here have been taken with HP435 Power Meter.
- 4 Gain and Noise Figure measurements made with HP8970A and 346A Noise Head

Scope of Document

This document is intended to provide all necessary information to guide users in the construction and installation of all variants of the G4HUP General Purpose Distribution Amplifier Model DA1-4 in normal operation.

Ready built units are supplied complete and tested, with a full test report.

This document is relevant for DA1-4 units constructed on GPDAV2.0 PCB's.

Reference data can be found on the DA1-4 pages of the G4HUP web-site, including any identified issues or problems – <http://g4hup.com/DA/DA1-4.html>.

DA1-4 Distribution Amplifier Versions

There are two key variants of the DA design:

- *High Level Distribution Amplifier*, intended primarily for distribution of 10MHz and other reference signals for test equipment and radio equipment frequency locking. Since there are inherently no frequency determining components in the basic design, it is broadband to a degree. Due to the high level of the input signal, typically around +10dBm, noise figure performance is not a critical issue. This variant will be referred to throughout this Manual as the DA1-4L
- *Low Level Distribution Amplifier*, with additional gain in front of the splitter and output amplifiers. This version has a much reduced noise figure, and is therefore better suited to RF distribution requirements, such as feeding multiple receivers from a single source, or boosting signal levels in paging and distribution systems. The nomenclature RFDA1-4 will be used to identify information for this version.

Further variations are possible by exercising features of the PCB design:

- *Daisy chain auxiliary output*: a -3dB output may be extracted for daisy chaining DA's – this is not recommended in the DA1-4L version, since there is limited gain available within the second DA to bring the output levels back to the nominal +10dB required.
- *Low Pass filtering*: provision is made on the PCB for a 5 pole Chebyshev LPF which can be implemented to remove any unwanted higher frequency signals, and avoid them being passed into subsequent systems. This option is placed before the Daisy Chain Aux output, so that this output will also benefit from the band limiting effect.

- *Band Pass filtering:* optionally the user may provide BPF to suit their application via two access points, allowing a sub-board to be mounted on top of the main PCB. This sub-board may carry a helical or LC BPF as the user requires. It is not planned to produce specific sub-board PCBs for this purpose.
- *Variable Gain Control:* a panel accessible variable gain control option can be installed, giving approx 20dB of gain variation. It is recommended that this is only implemented on RFDA versions, since the placement is in front of the splitter, and therefore any excess loss introduced adds directly to the noise figure of the system. Where possible, it is recommended that attenuators to set output levels are installed on the output of each channel individually.
- *Output Attenuators:* as referred to above, each channel of the output has provision for Pi type resistive attenuators to be installed. Outputs can be set to different levels as required by the systems they are feeding. Of course any unused outputs should be correctly terminated in 50R.
- *Input connector power feeding:* the input connector can be configured to provide a DC supply of up to approx 80mA, allowing it to power active antennas. The voltage can be set by choice of regulator.

DA1-4 Distribution Amplifier Description

The variants of the Distribution Amplifier are based on the GP DA V2.00 PCB

GP DA V2.00 PCB Description

The PCB is developed from the V1.00 DA PCB's, and the functional blocks are shown in Fig 1. Blocks 5 to 13 are identical to the previous version, and form the core split and output amplifier functions. Block 14 is the power feed circuit for active antennas, also present on the earlier boards. These blocks are adequate for dealing with relatively high level signals, such as 10MHz distribution.

Blocks 1 to 4 are new items, and each can be implemented as an option:

- Block 1 is an input amplifier. This allows more gain to be achieved, and also defines a lower noise figure for the amplifier as a whole. It is recommended for applications where low-level RF signals need to be distributed, and the NF is low enough for the unit to be used as an antenna distribution amplifier.
- Block 2 is an on-board 5 pole low-pass filter. This recommended for use in 10MHz systems to remove any harmonics which may cause difficulties in reception of weak signals on the odd harmonics, eg 50MHz and 70 Mhz particularly. Components are supplied as standard with DA1-4HL versions to implement a 5 pole Chebyshev filter with a roll off just above 10MHz. No filter components are supplied with DA1-4RF versions, but advice and components are available on request.

- In parallel with the on-board filter, through board connections are included to allow the implementation of an alternative external filter above the PCB. This will allow use of either helical (eg Toko 5HW or 7HW types), or custom LC designs. The amplifier can thus be constrained in bandwidth for customer applications, limiting the risk of any high level out of band signals being delivered to subsequent stages or systems.
- Block 3 is an optional 2 way resistive splitter which can be used to provide an Auxiliary out for daisy-chaining devices. Implementing this function does degrade the noise figure, so it should be used with care. It is recommended that this is not implemented on DA1-4HL models unless there is excess input signal that enables the extra through loss to be tolerated.
- Block 4 is a 20dB variable attenuator, adjustable from the front panel of the DA. It is recommended that this is only used on DA1-4RF versions where adjustment of level is essential in service. Overall device noise figure is degraded as the attenuation is increased. For installations where no adjustment is anticipated, it is strongly recommended that gain reduction is done in the output attenuators of each stage, where it will have no negative effect on the noise figure.

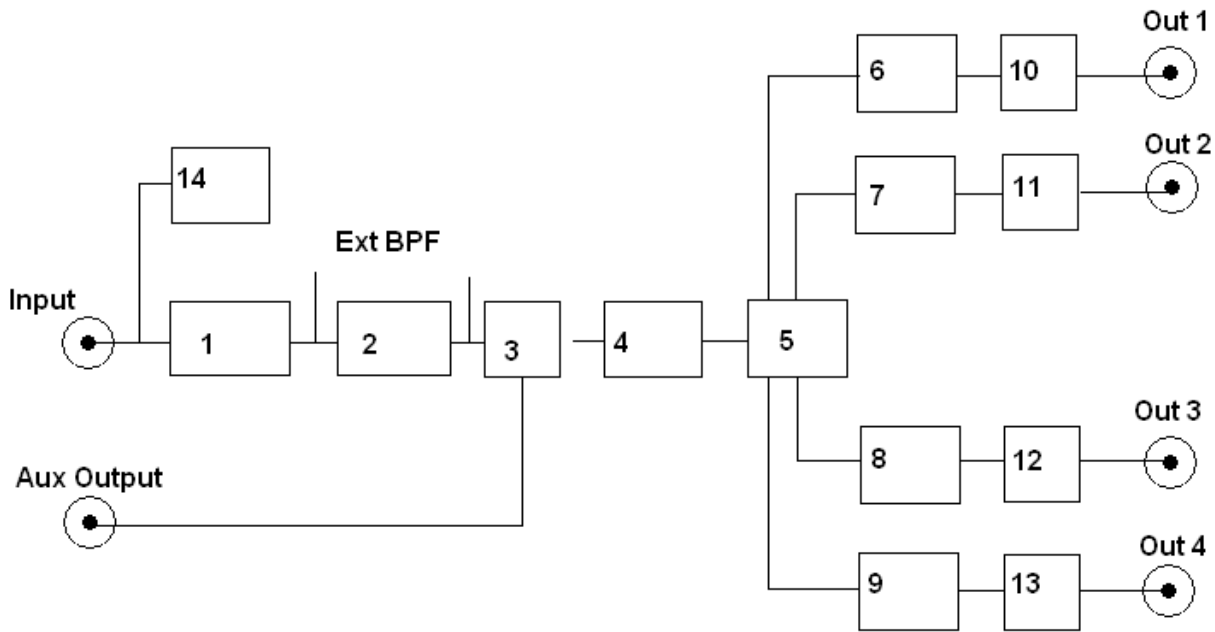

1	Input amplifier	5	4 way resistive splitter
2	On board LPF/Attenuator	6 - 9	Output amplifiers
3	Optional splitter	10 - 13	Output attenuators
4	Optional 20dB variable Attenuator	14	5v bias tee for active antennas

Fig 1 – GP DA V2 PCB Block Functions

Fig 2 shows the V2.00 PCB with the functional areas highlighted.

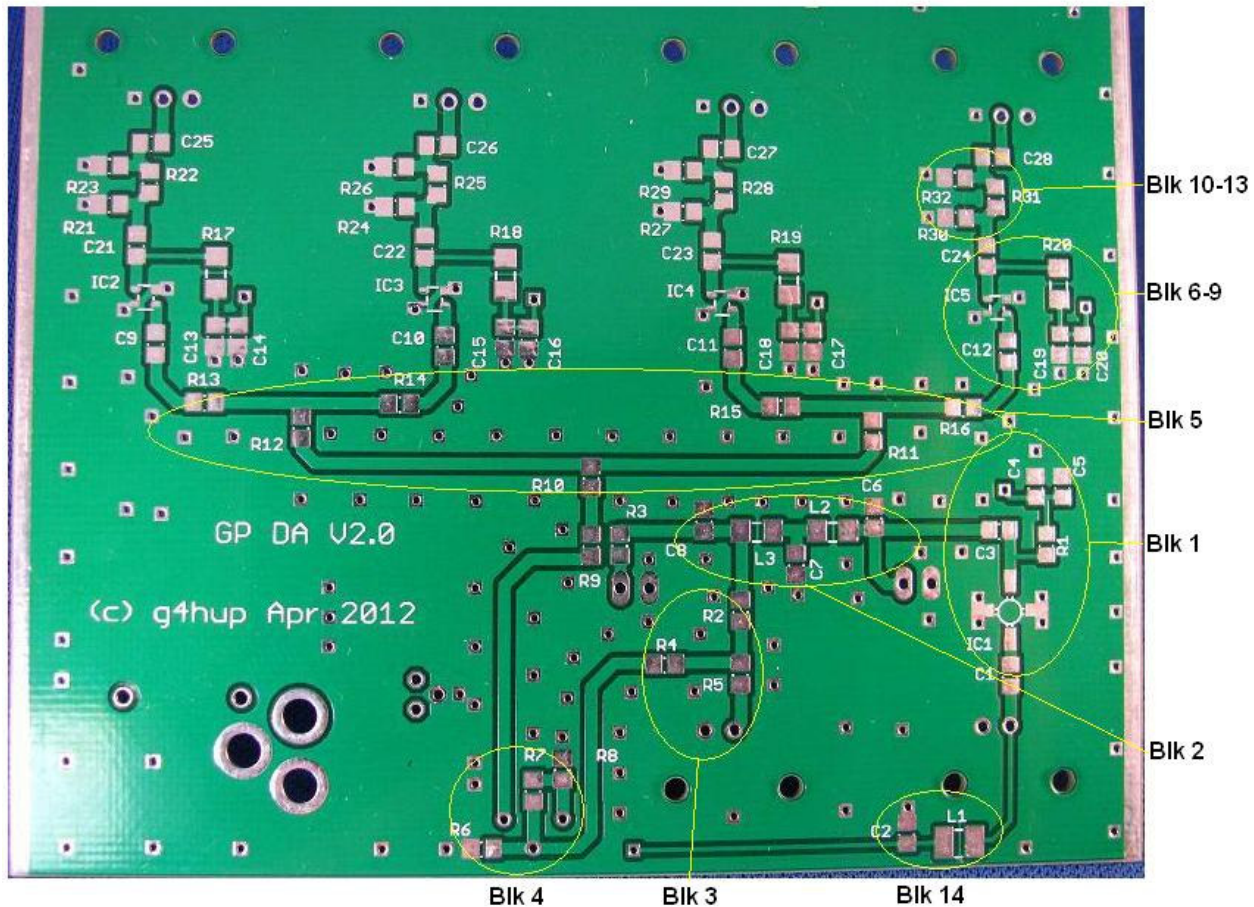

Fig 2 – GP DA PCB lower side view showing functional areas

Unused Channels

Where less than 4 output channels are required, there are two options:

- Construct the full DA1-4 and simply terminate the unused channels in 50R BNC terminations. This provides the best flexibility
- Only construct the required number of channels. This can achieve lower current consumption, so may be attractive in certain situations. In this case, each unwanted output of Block 5, the 4 way splitter, should be terminated in 50R to ground ie after R13, 14, 15 or 16 as appropriate. The remainder of the components for any unwanted channels can be omitted.

Version - DA-HL

The DA1-4HL is a single input 4 output broadband distribution amplifier system. Its frequency response can be tailored by installation of suitable LPF or BPF filters. Typical gain at 10MHz is approx 5dB in each channel, which decreases to 0dB at approx 1.5GHz.

As supplied the DA1-4HL implements blocks 5 to 13 from Fig 1, and components are supplied for a 10MHz LPF to be placed in block 2. Other frequency filter components may be requested.

Due to the resistive splitter, it is not recommended that either the Aux output (block 3) or Variable Attenuator (block 4) functions are implemented on this version, and components for these are not supplied not included in the standard kit.

Whilst the Input socket power feeding option (block 14) can be implemented on this version to power active antennas, it is recommended that the DA1-4RF is used for such applications due to the lower noise figure.

Typical Applications

- Distribution of reference signals such as 1MHz, 5MHz and 10MHz for frequency/time synchronisation of test equipment and communications equipment.

Version – DA-RF

The RFDA is designed as a 1 input 4 output broadband amplifier system. Its frequency response can be tailored by installation of suitable LPF or BPF filters. Significant gain is still available at 2GHz, although the noise figure is increasing.

The standard kit for the DA1-4RF includes components for all blocks shown in Fig 1 with the exception of block 2, the LPF. Components may be requested for specific frequencies. All the options block 2 through to block 4 may be provided or bypassed as required.

The input amplifier is implemented using a SiGe MAR-6. Substituting other devices in the same or compatible packages may give better performance for specific applications – ie improved noise figure, or different gain. Currently no testing has been carried out with alternatives.

It is recommended that the Variable Attenuator function is only implemented where it is anticipated that changes of attenuation will be required 'in service'. It is preferred that any fixed attenuation is provided using the Pi attenuator pads provided in the output of each individual amplifier, since this will have less effect on the overall noise figure of the device.

Typical Applications

- distribution of RF sources to multiple destinations, eg enabling a 144MHz (or 432MHz) microwave IF to be routed to more than one receiver simultaneously, or routing a common LO source to multiple converters.

- distribution of a GPS antenna feed to multiple GPS receivers – optional components allow the DA1-4 to provide the +5v 80mA power feed for active GPS antennas – fixed attenuators may be needed in the output stages to avoid overloading the GPS receivers.
- use as a line booster/multiplexer for paging systems, allowing extension of system coverage
- antenna distribution in VHF and UHF systems for multiple receiver/common antenna applications.

Sundry Information

Filtering & Isolation

No isolation transformers are used within the DA PCB – should isolation be required this must be provided externally by the user.

On board filtering can be provided on the the PCB. For radio workshop locations where receiving systems are installed, it is recommended that LP filters are installed in 10MHz DA systems. This reduces the harmonics of 10MHz that may be radiated through leakage from the coaxial distribution cables. Such harmonics make reception of weak signals on integer multiples of 10MHz (eg 50MHz, 70MHz) impossible.

The standard filter implemented with DA1-4HL kits has a knee frequency of 12MHz, to ensure minimum loss at 10MHz – the response of the filter is shown in Fig 6.

Connectors

All variants use right angle PCB mounting fully screened BNC connectors.

Output Phase Equalisation

Precautions have been taken in the PCB layout to equalize the path lengths of the four signals, so that the phase variation between the output channels is minimal – measurements made at 10 MHz indicate that this considerably less than $\pm 3^\circ$. The variations will be different at other frequencies, and users are recommended to make their own measurements if phase differences are a significant concern in their specific application.

Physical Description

The DA1-4 is housed in an extruded aluminium case, measuring 109 x 80 x 30 mm (4.375 x 3.2 x 1.2 inches approx)

External connections are provided for:

- Input signal - BNC
- Output signals – 4 x BNC
- 2.1mm DC power connector
- Optional (RFDA only) – Auxiliary output daisy chain - BNC

Version Construction Notes

DA1-4HL

No PCB preparation is required other than Errata 1 for all occupied BNC locations.

Fig 7 shows the complete circuit diagram, and Figs 8 and 9 show the underside and top side component locations.

- Mount the SMD capacitors first, then the resistors.
- Use 0R links (supplied) at C3.
- Bypass IC1 using a short length of wire
- Install the appropriate LPF values at C6 to 8 and L2, 3. If no LPF is to be used, then replace L2,3 with 0R links
- Link R3 to R9 as shown in Fig 3A below (this bypasses the aux output and variable gain stages, Blocks 3 and 4).
- Attach IC2, IC3, IC4 and IC5.
- Turn the PCB over and mount the regulator components C29 to C32, and IC6. Take care with the polarity of C30 and C32 – the end showing the bar is +ve
- Install D1
- Locate the five BNC sockets in position and solder from the underside – for the four output sockets, X2 to X5, you may find it easier to mark and drill the panel first. Then all four sockets can be assembled to the panel, and will be held in place as one unit while you solder them to the PCB
- Locate the power connector J1 in position and solder from the underside.

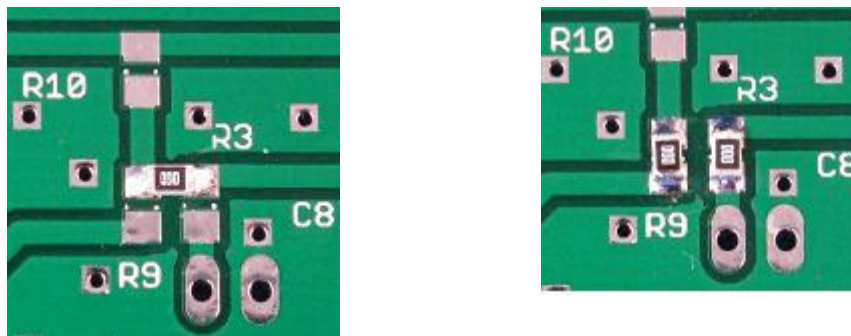

A – variable attenuator bypassed

B – variable attenuator active

Fig 3 – R3/R9 signal routing options

Initial testing can be carried out before setting any attenuators in the circuit. Bypass each output attenuator using a 0R link (supplied) in place of R22, R25, R28 and R31.

Connect DC power to the 2.1mm power connector via the supplied lead – note that the wire with the white stripe is the **positive** side!

Attenuator values: once initial measurements to confirm gain at the frequency of operation have been made you can determine the attenuator values that you need to use. It is strongly recommended that you use the output attenuator options as the preferred location, and individual values may be set in each channel according to need. Any unwanted channels (eg where only a 2 way or 3 way split is needed) can be permanently terminated in 50R, and the BNC connector omitted. Use locations R21, R24, R27 or R30 for the 50R. A table of resistor values to create Pi attenuators is given in Appendix 1

Where absolutely necessary, there is a further option to create an attenuator on the input side of the DA. In this instance 0R links should be put in R2, R4 and R9 positions. A Pi attenuator may then be built using R6 and R8 for the shunt resistors and R7 for the series resistor, as shown in Fig 4. Be aware that an attenuator in this position (ie before the amplifiers) will degrade the noise figure of the DA by the amount of attenuation introduced.

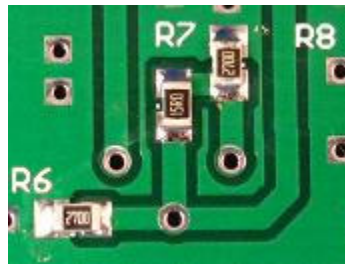

Nominal 3dB attenuator in place of variable attenuator option

Fig 4 – building an optional attenuator in place of the variable attenuator

DA1-4RF

Construction is as for the HL version, with the addition of:

- Insertion of IC1 and the associated components C3, C4, C5 and R1

Any or all of the following options can be implemented as required.

For the Filter:

- install appropriate values for L2, L3 and C6 to C8, or
- use a daughter board via JP1 and JP2 for an alternative LPF arrangement of a BPF – in this case install 0R at R3 as well

For the Aux output:

- install R2, R4 and R5 (all 16R) and socket X6
- If the variable attenuator option is not required, then bridge the slider of P1 to the track to R9 as indicated in Fig 5
- Install 0R at R9

For the Variable Attenuator:

- Install 0R at R2 and R4 if Aux output is not required
- Install 220R at R7 and 47R at R8
- Install P1
- Install 0R at R9

For Active Antenna power feed:

- Install L1 and C2
- Install IC7, C33 and C34 on the top side of the PCB

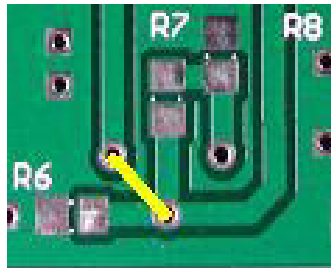

Fig 5 – Bridging out the Variable Attenuator stage

Case Preparation

The PCB simply slides into slots in the extruded case. Front and rear panels must be drilled to accommodate the BNC connectors and power connector. If the variable attenuator option is installed you will also need a hole for making the adjustments.

You can use the supplied guides either as 'stick-on' overlays, or as information sources to do your own measuring and marking.

It is recommended that you download and print the separate Drilling Overlay to ensure accuracy

Fig 10 is a drilling guide for the front panel. Note that the aluminium panels are **not** symmetrical! Take care to get the panel the right way up before you mark out the drilling positions!

Fig 11 is the rear panel drilling guide – the same warning applies here!

In both cases, mark and drill only holes required. For all versions the rear panel is the same (4 x BNC) but the front panel is version dependent:

All versions need the input BNC and the power connector holes.

If you have the RF version, you may also need the Aux Out BNC and the Variable Gain adjustment holes depending on what options you are building.

Once the holes are de-burred, slide the finished PCB into the case, and mount one of the panels. Fasten it with the small self-tapping screws provided, and secure the BNC connectors via their nuts and washers. The assembly is now secure, and the second panel can easily be put in place and the screws tightened up.

The four rubber feet can be attached to the underside of the case.

Finally, remove the backing from the adhesive label and install it on the top of the case -make sure you get it the right way round!

Errata and Addenda

This section contains information about components that have been changed or added compared with the original PCB design.

1 V2.0 PCB – remove solder mask around the location lug holes of each of the BNC socket positions – due to a design oversight, there was no tinning applied in manufacture. This will be rectified on V2.01 PCB's

See <http://g4hup.com/VDA/DAerrata.html> for full details, versions impacted and resolution guidance, including pictorial support.

Component Locations

Figs 8 and 9 respectively show the locations of components on the top side and lower side of the PCB

Performance - DA1-4HL

Fig 12 shows the swept frequency response between 10MHz and 1.8GHz. There is some variation at higher frequencies between outputs. Note that all unused outputs should be terminated with a good 50R load.

Through the VHF region there is positive gain, with a dip between approx 500 and 800MHz. Thus the DA1-4 is usable up to the 70cm (430MHz) amateur band, and again through the 33cm (US 902MHz) and 23cm (1296MHz) amateur bands. However, it is not recommended that it is used at the higher frequencies since the noise figure is very high – for such applications, the DA1-4RF version is recommended.

Fig 13 shows the output signals from all four channels when the DA1-4 is driven at 10MHz. This display is set so that 1 complete cycle covers 10 divisions of the screen – thus 1 division equates to 36° of phase. The crossings of all four channels are very close at the div 10 point, (ie after 1 cycle) indicating that the differential phase error is very small – less than $\pm 3^\circ$ (ie within 0.2 div).

Maintenance

Construction Practices

Kits are not supplied with any solder, but it is recommended that a small diameter, good quality cored flux solder is used, to ensure minimum flux residues on the PCB after assembly. The PCB will accept lead-free solder, and components used are generally ROHS compliant, and should therefore also accept lead-free solder if you prefer.

It is recommended that lead based solder is used for maximum reliability of soldered joints.

Change History

Date	Iss No	Comment	Author
9 Jun 2008	0.A	First Draft version	G4HUP
31 Jul 2008	0.B	Updated, performance measurements included	G4HUP
15 Feb 2009	V1.0	Updated for production PTH PCBs	G4HUP
16 Feb 2009	V1.01	L and G version detail clarified	G4HUP
25 Oct 2011	V1.02	Corrected errors in component values on schematic diagram	G4HUP
4 Jun 2012	V2.00	Revised to reflect new production and options	G4HUP
8 Jun 2012	V2.01	Minor corrections and updates	G4HUP
3 Dec 2014	V2.02	BGA616 Bias resistors increased to 68R	G4HUP
13 Aug 2015	V2.03	Fig 10 modified for Low Profile BNC sockets	G4HUP

End of text – Diagrams follow

Component List DA1-4HL

ID	Value	Spec	Comment
PCB	GPDA	V2.0	
Box			
X1 - X5		BNC	Right Angle
J1	2.1mm		DC Power PCB mtg
C1, 9-12, 14, 16, 18, 20, 21-29, 31	100n	0805/50v	
C6, 8	330p	0805/50v	
C7	560p	0805/50v	
C13, 15, 17, 19	10n	0805/50v	
C30	10u	25V	
C32	10u	16v	
R10, 13 - 16	16R	0805/ 0.125W	
R3	0R	0805/ 0.125W	
R11, 12	33R	0805/ 0.125W	
R17 - 20	68R	1206/ 0.2W	
R21 - 32	SOT	0805/ 0.125W	4 x 0R supplied
L2,3	1uH	1008	
D1	1N4001		DC Protection
IC2 - 5	BGA616		
IC6	78M08		

Note – 1 x 33R and 2 x 180R also supplied
 – these can be used to build 5dB attenuator in place of LPF if preferred

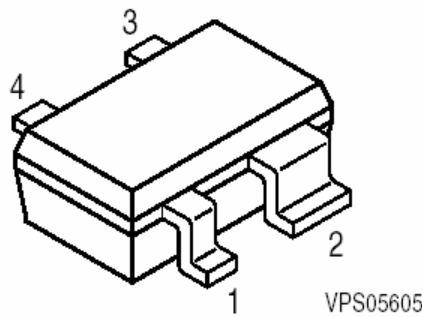

BGA 616 connections

Input – pin 1
 Output pin 3
 Ground pins 2,4

Pinout data courtesy of Infineon BGA616 data sheet.

Component List DA1-4RF

ID	Value	Spec	Comment
PCB	GPDA	V2.0	
Box			
X1 - X5	BNC	Right Angle	
J1	2.1mm		DC Power PCB mtg
C1, 3, 4, 9-12, 14, 16, 18, 20, 21-29, 31	100n	0805/50v	
C6, 8	SOT	0805/50v	
C7	SOT	0805/50v	
C5, 13, 15, 17, 19	10n	0805/50v	
C30	10u	25V	
C32	10u	16v	
R1	150R	0805/ 0.125W	
R10, 13 - 16	16R	0805/ 0.125W	
R2, 3, 4, 9	0R	0805/ 0.125W	
R11, 12	33R	0805/ 0.125W	
R17 - 20	68R	1206/ 0.2W	
R21 - 32	SOT	0805/ 0.125W	4 x 0R supplied
L2,3	SOT	1008	
D1	1N4001		DC Protection
IC1	MAR-6		SiGe type
IC2 - 5	BGA616		
IC6	78M08		
Options			
X6	BNC	Right Angle	Aux output
R2, 4, 5	16R	0805/ 0.125W	Aux output
P1	500R		Var Atten
R7	220R	0805/ 0.125W	Var Atten
R8	47R	0805/ 0.125W	Var Atten
C2	1n	0805/50v	Active Antenna
C33	100n	0805/50v	Active Antenna
C34	10u	16V	Active Antenna
IC7	78L05	TO92	Active Antenna
R6	SOT	0805/ 0.125W	Fixed att (R7, R8)

26 Apr 2012

Ansoft Corporation
XY Plot 1
Circuit1

00:33:56

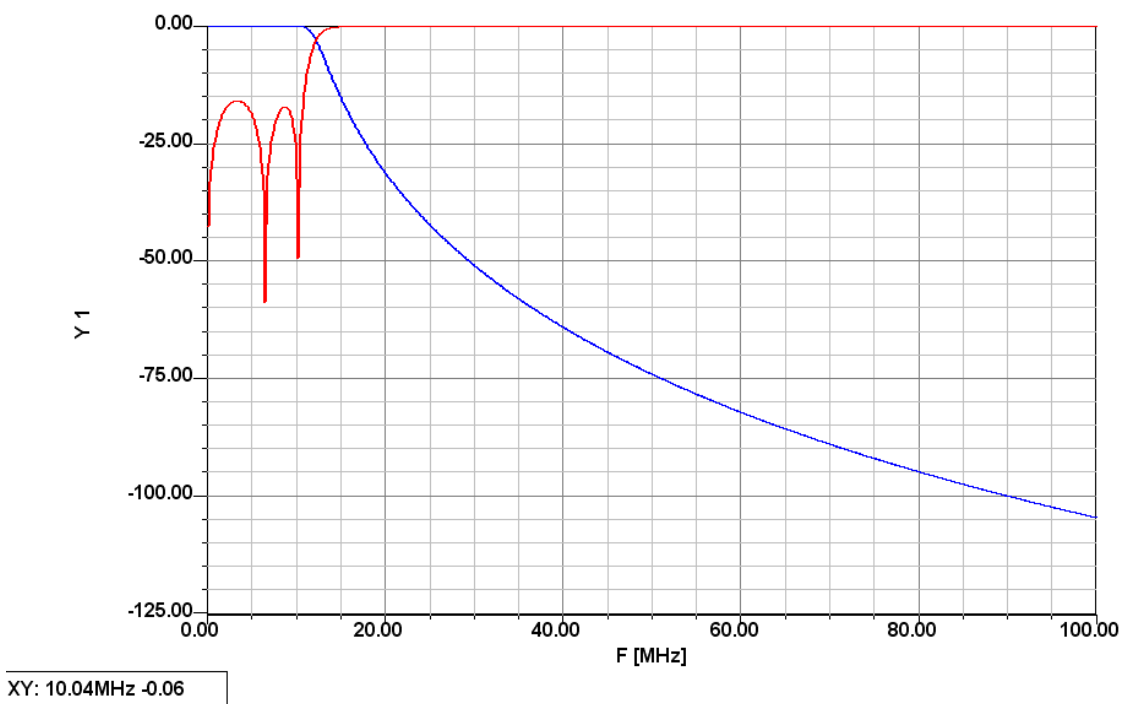

Fig 6 – 10MHz Low Pass Filter response

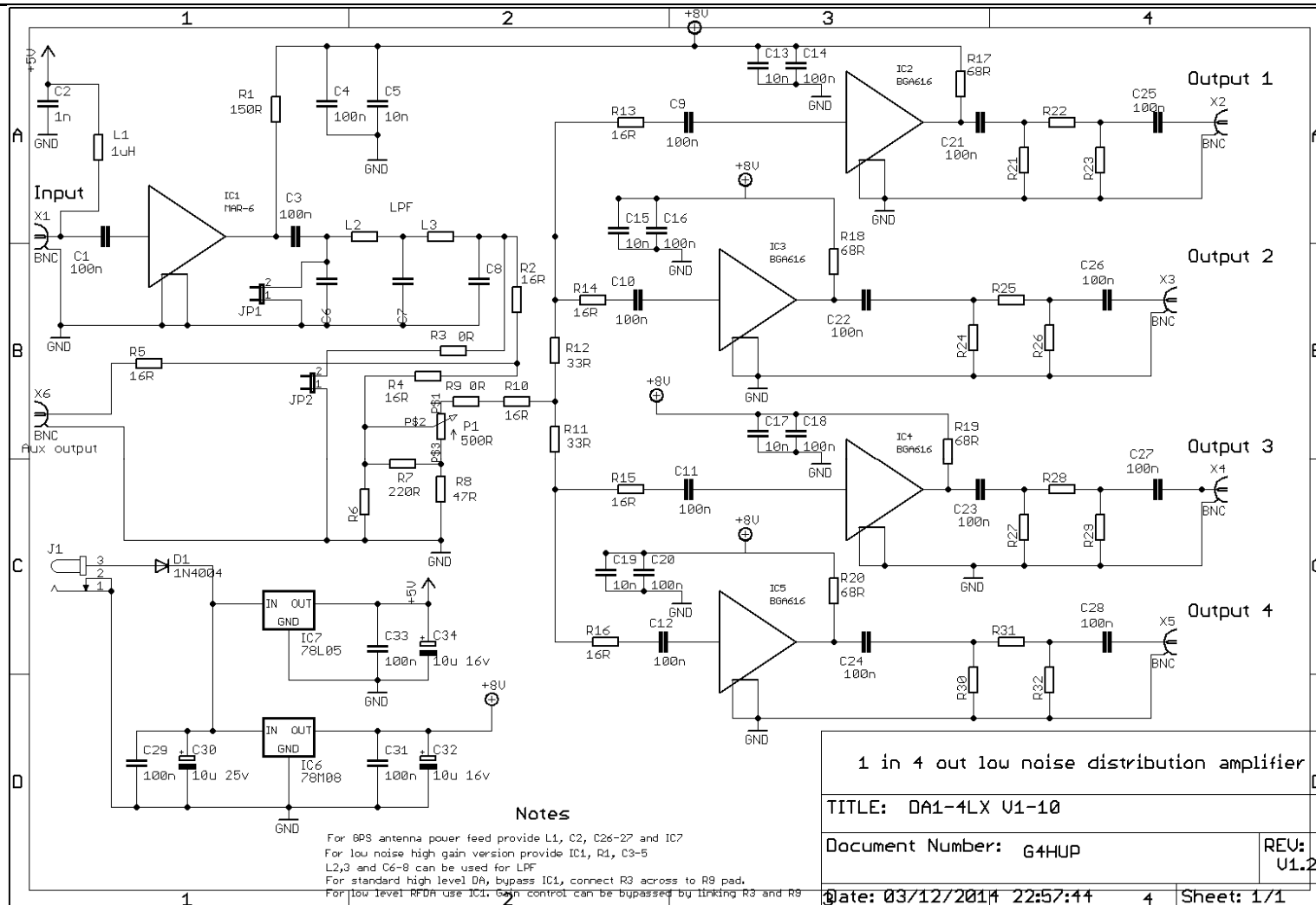

Fig 7 – General Purpose Distribution Amplifier circuit

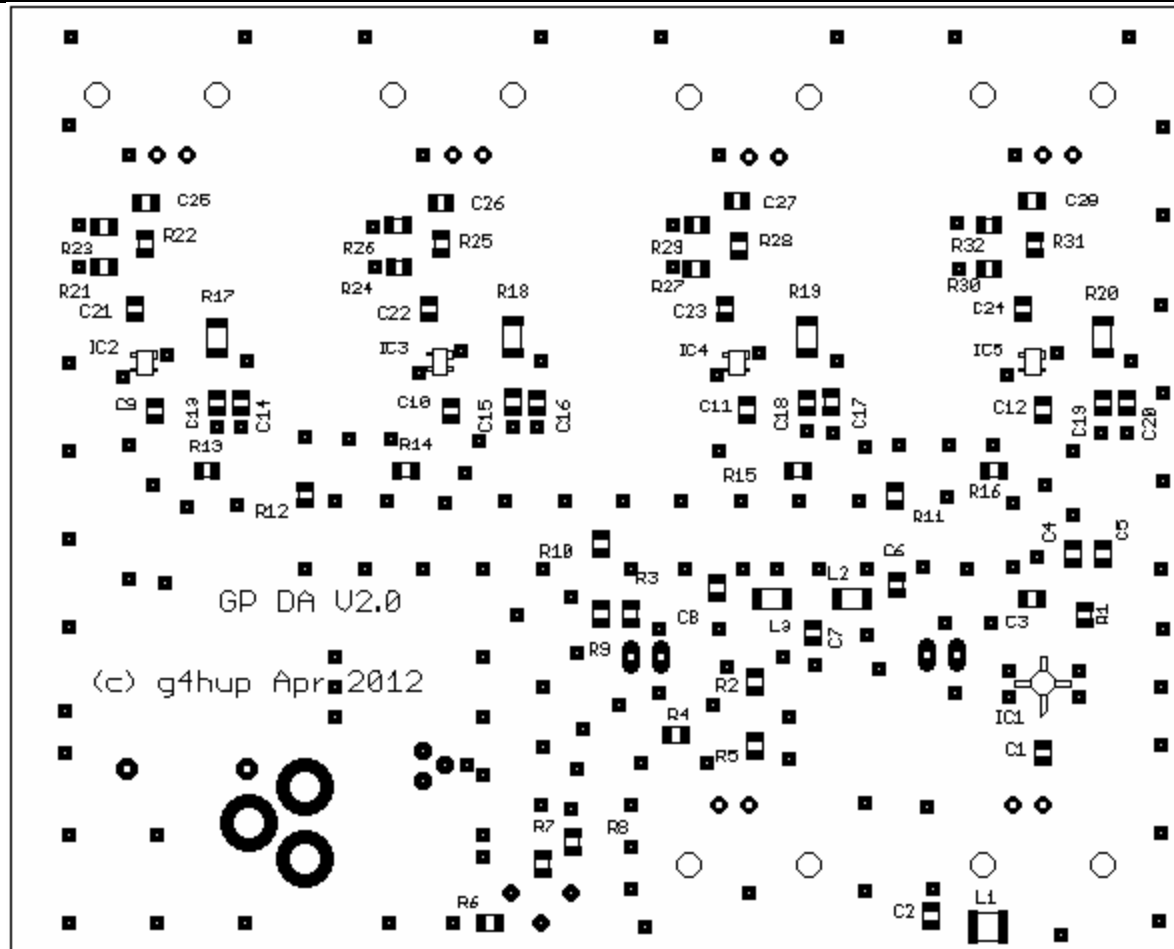

Fig 8 – PCB Component side Locations

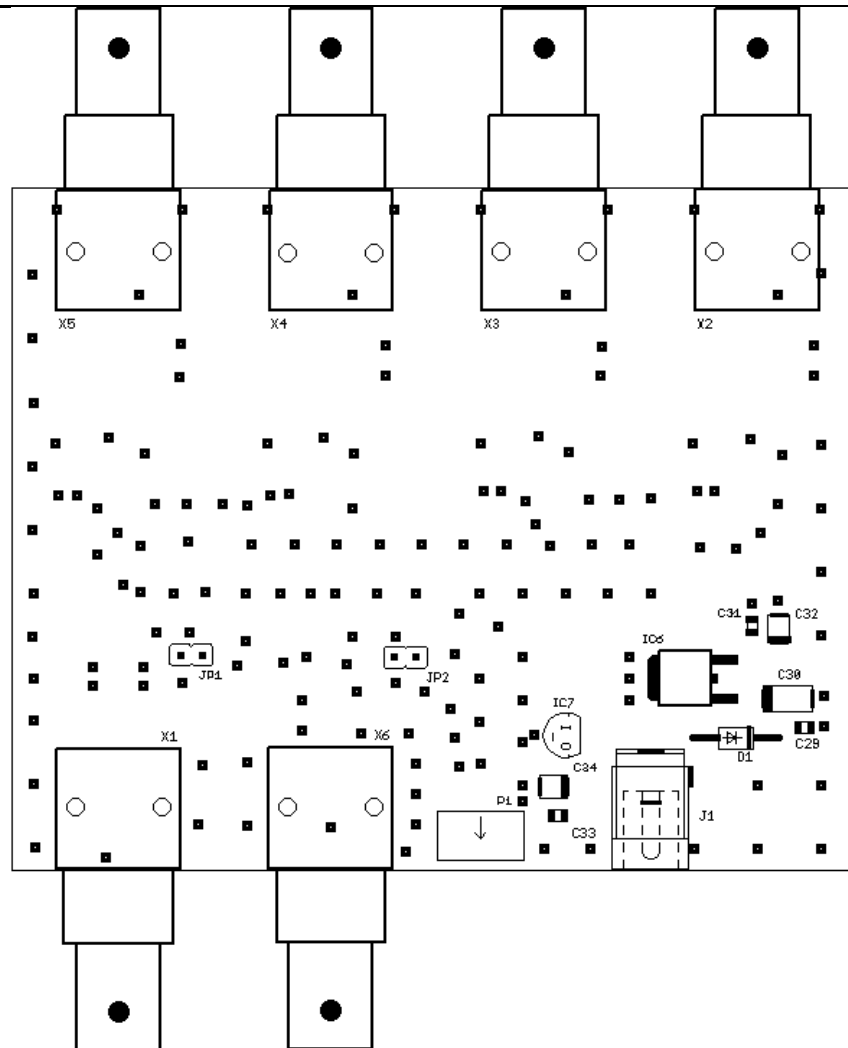
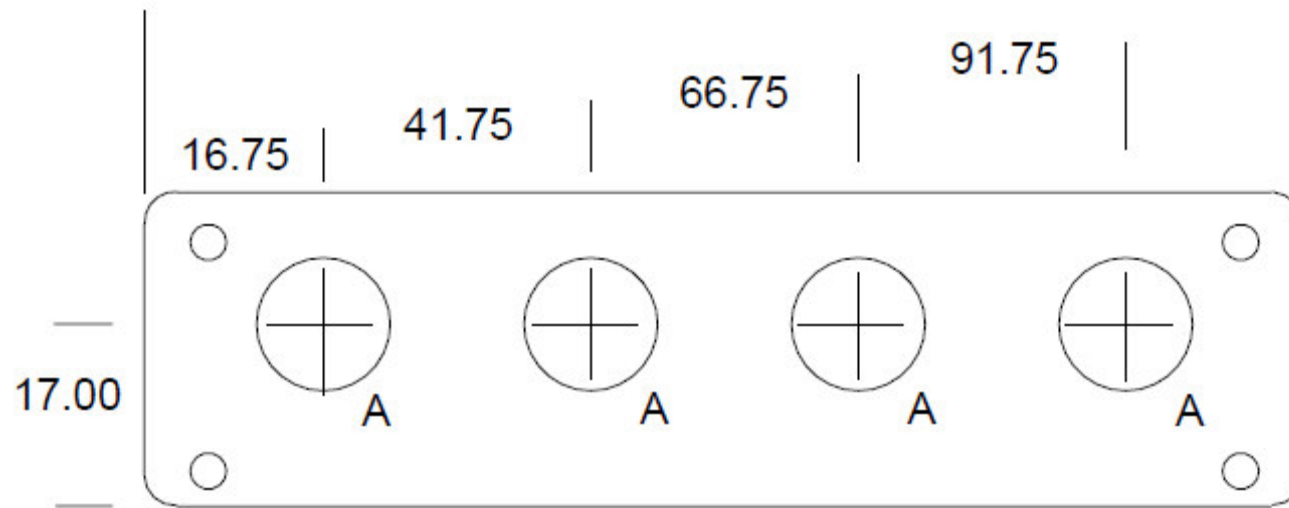

Fig 9 – Top side PCB overlay



CAUTION!! Blank panel is not symmetrical - ensure that screw holes are offset as shown
17mm dimension shown above applies to standard BNC sockets; where Low Profile sockets are supplied, this should be reduced to 15mm on both front and back panels

– view shown is as seen from outside case

All dimensions in mm
A – 12.5mm dia; B – 5mm dia; C – 8mm dia

Fig 10 - Front panel drilling guide

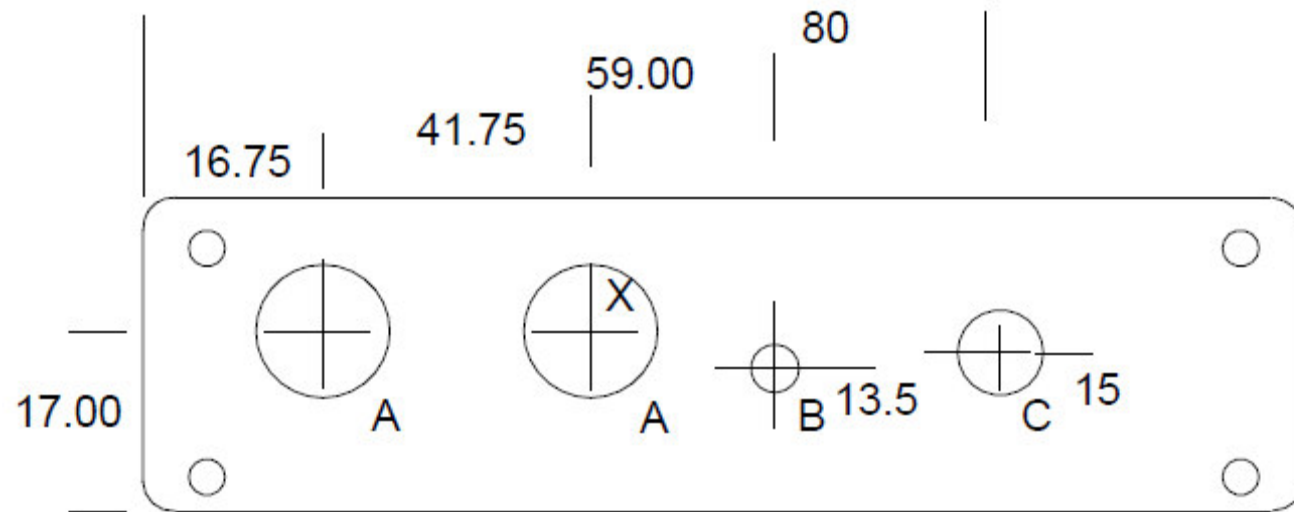

This line to be 50mm long when printed

- CAUTION!! Blank panel is not symmetrical
- ensure that screw holes are offset as shown
 - view shown is as seen from outside case

Fig 11 – Rear panel drilling guide

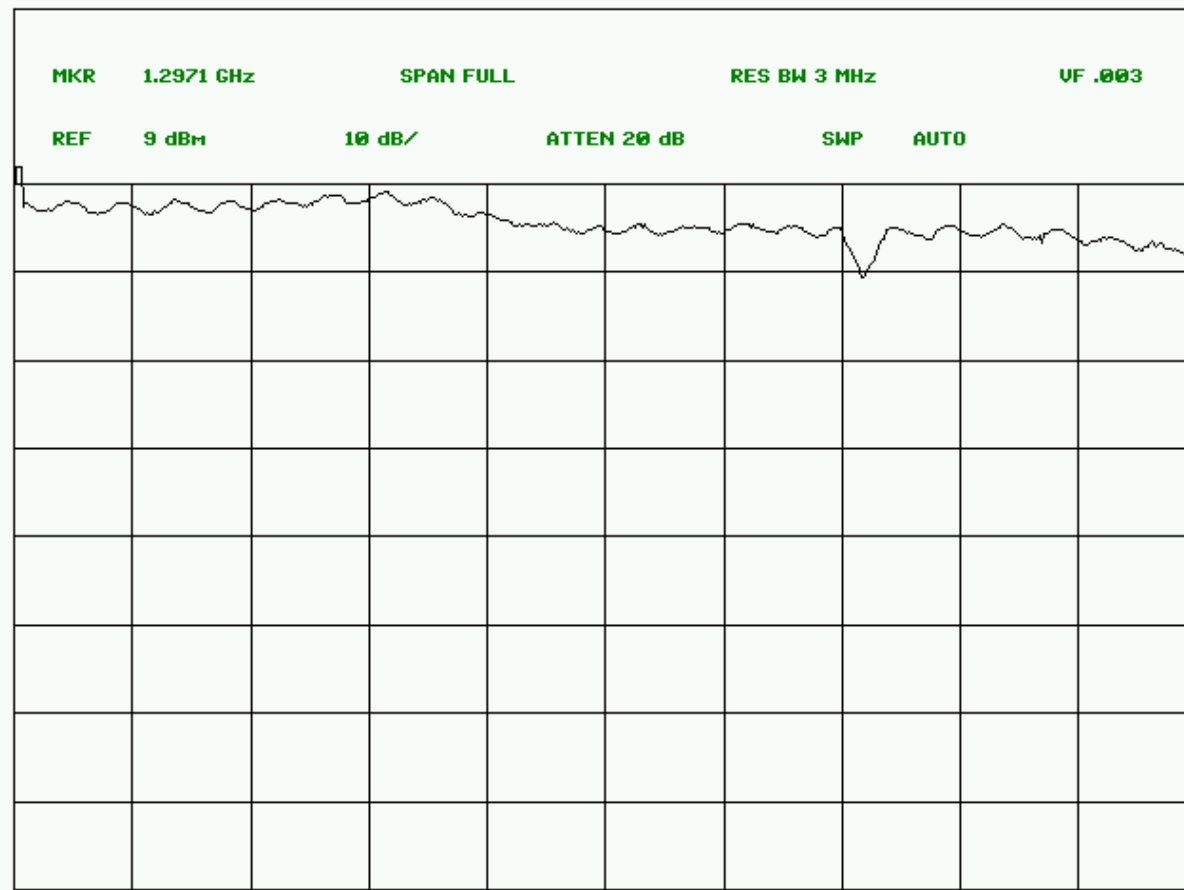

Fig 12 – DA1-4 swept frequency response from 10MHz to 1800MHz, with 5dB input attenuator.
Input level +10dBm, 0dbm output ref is top of grid. Marker is at approx 1297MHz
Measurement levels here are nominal

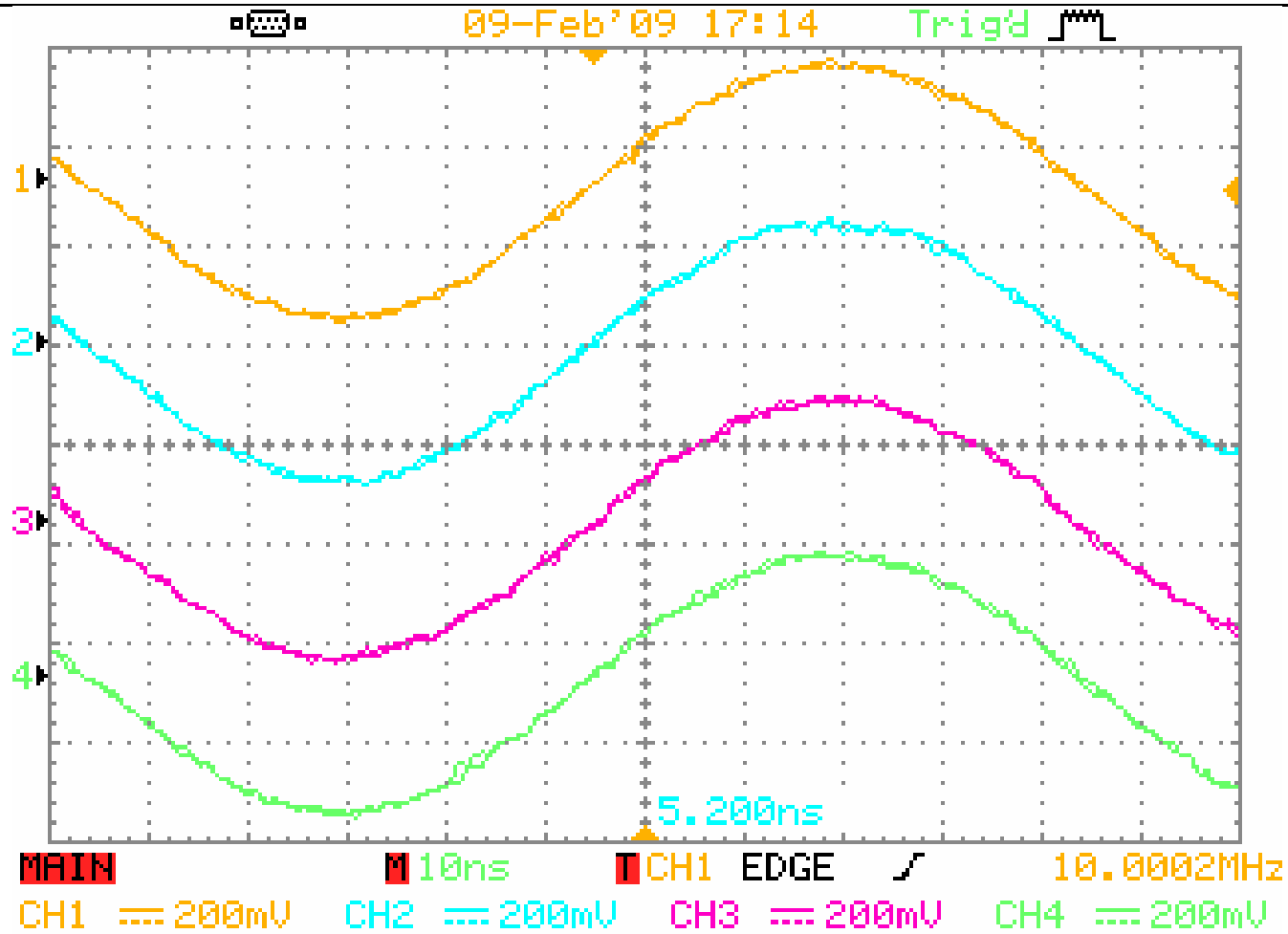

Fig 13 – Phase variation between output channels at 10MHz

– 1 cycle = 10 div, 1div = 36°

Appendix 1 – Pi Attenuator Resistor Values

The following table gives data for construction of resistive Pi type attenuators. It is taken from the RSGB published Microwave Handbook, Volume 2, page 10.6. In the table R1 refers to the shunt resistors to ground (2 off) while R2 refers to the series resistor.

Many of the values are not readily available within the standard E24 series – so if you decide not to use precision resistors, but to round the values to suit availability, then you should round both R1 and R2 values in the same direction – ie up or down, to preserve the correct ratio. However, this will result in the impedance being slightly away from the intended 50R.

dB	R1	R2
1	870	5.8
2	436	11.6
3	292	17.6
4	221	23.9
5	178	30.4
6	150	37.4
7	131	44.8
8	116	53
9	105	62
10	96	71
12	84	93
14	75	120
16	69	154
18	64	196
20	61	248
25	56	443
30	53	790

Table A1 – Pi Attenuator resistors